

ROYAL[®]
ELEVATORS

PASSENGER LIFT
(CENTER OPENING AUTO DOOR)

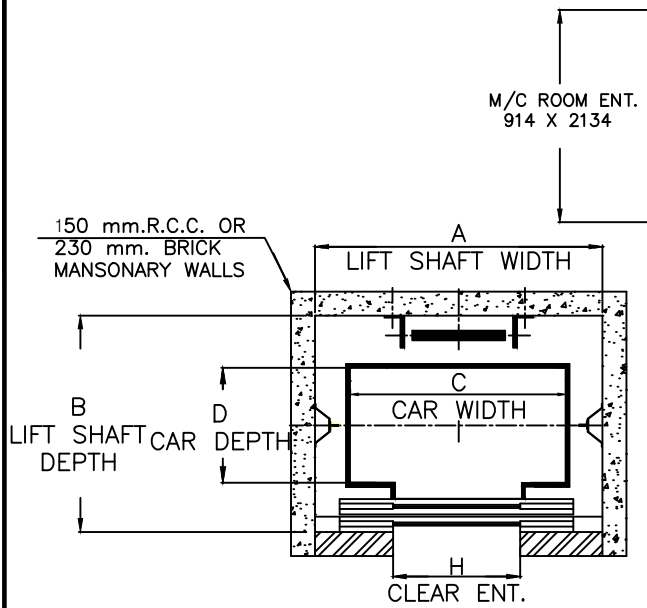

LIFT HOISTWAY PLAN

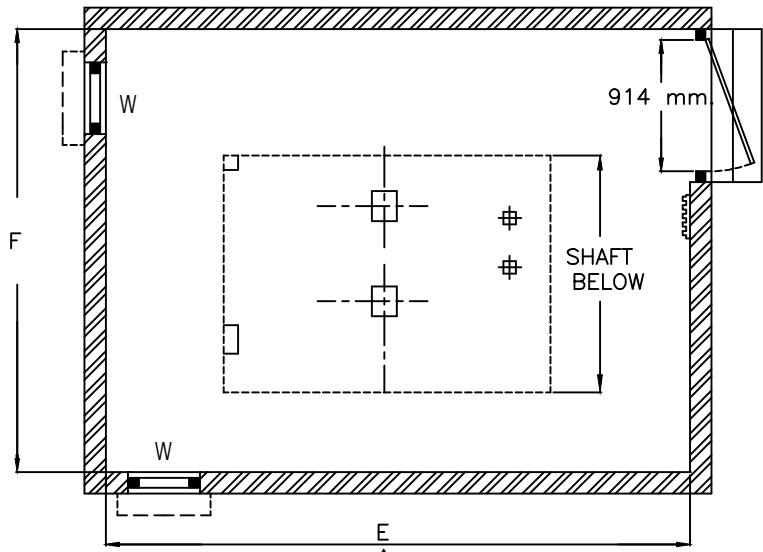

MACHINE ROOM PLAN

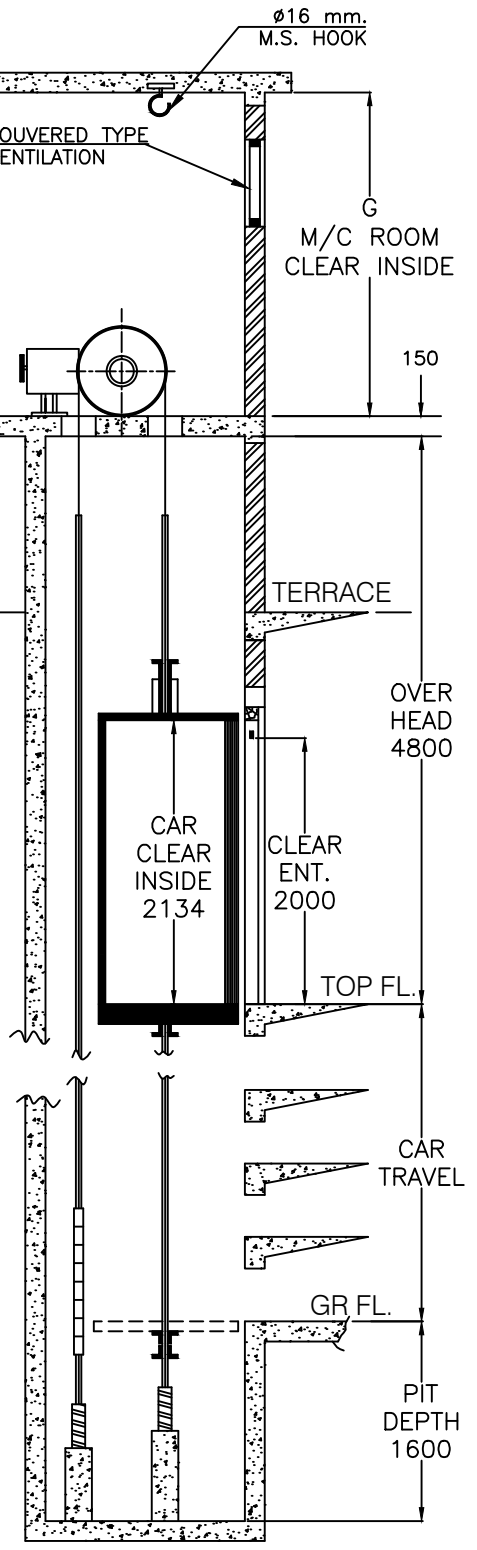

SECTIONAL VIEW

LOAD		LIFT SHAFT		CAR INSIDE		MACHINE ROOM		CLEAR ENT.	
PERSONS	KGS	A	B	C	D	E	F	G	H
6	408	1700	1600	1200	900	3500	2440	2500	700
8	544	1850	1850	1300	1100	3660	2440	2500	800
10	680	1900	2000	1300	1350	3660	2440	2500	800
13	884	2400	2000	1800	1200	3660	2440	2500	900
16	1088	2500	2000	2000	1300	3660	2440	2500	1000

SPEED :- 1.00 m.p.s. ABOVE DIMENSIONS AS REQUIRED BY ALL DIMENSIONS ARE IN MM.
PIT DEPTH :- 1600 mm. LIFT ACT. BOMBAY & IS 14665

IMP NOTE :- FRONT WALLS TO BE CONSTRUCTED WITH OUR INSTRUCTIONS ONLY NOT TO SCALE

THIS DRAWING AND DESIGN IS THE PROPERTY OF ROYAL ELEVATORS AND MUST NOT BE COPIED OR LENT WITHOUT OUR PERMISSION IN WRITING